

ORBOT®

LiFe

I POWER 20 LITHIUM-ION HYBRID POWERED



2023

OPERATING MANUAL

CE

WARRANTY

All ORBOT equipment has been carefully tested and inspected at our SMT Factory. ORBOT Life machines are guaranteed for 2 years warranty (this excluded the batteries I Power 20, the warranty on the batteries is 800 cycles or 2 year) from the date of original purchase against defects or workmanship made during manufacture. Within the guaranty period we undertake at our discretion, to send replacement parts free of charge including transport so with the provided repair parts the machine unit can be made in his original production state with subject to the following conditions :

- Claims made under the terms of warranty must be supported by the original invoice issued at the time of sale along with the machine serial number.
- For claims made under this guarantee contact the supplier from whom you've purchased the machine, battery or charger systems he will take the needed actions for the warranty parts.
- Do not initially return the product as this could lead to transit damage.

Neither ORBOT nor his distributors will be held responsible for any incidental or consequential loss.

This guarantee does not cover:

- Periodic maintenance, repair or replacement of parts due to normal wear and tear.
- Damage caused by accident, misuse or neglect, fire or fitting other than genuine ORBOT parts. Defects in other than genuine ORBOT parts, repairs, modifications or adjustments made other than ORBOT partner service engineer or authorized service dealer.
- Cost and risks of transport relating directly or indirectly to the warranty of this product.
- PCB boards, engines and batteries when in the technical review is seen water has entered the components. Warning do not use high pressure units to clean the machine as this can lead to direct damage the this components by the high pressure of the water.
- -Consumable items such as brushes, drivers, Velcro discs, gliders, pars and so forth.

MACHINE DATA

Model: _____
Serial: _____
Date of Purchase: _____
Dealer: _____
Address: _____
Phone Number: _____
Sales Representative: _____

ORBOT®

Orbot Global B.V.

Lage Zijde 3
5626 DL Eindhoven
The Netherlands

+31 40 266 24 94
hello@orbotglobal.com
www.orbotglobal.com

TABLE OF CONTENTS

Warranty	2
EC Declaration of Conformity	
How to Use This Manual	4
Safety - Important Instructions	5 - 7
Technical Details	8
Operation	9 - 17
Unpacking and Initial Operations	9
Pre-Run Inspection	
Battery Charging & Installation	
On-Board (Hybrid) Charging	10
Battery Only Operation	
Battery Maintenance	
Spray System Preparation	11
Spray Jets	
Adjusting Height	
Process of Cleaning	
End of Application	12
Storage	
Lifting and Carrying	
Weight Kit Installation	13
Brush Installation	
Attaching and Removing the Driver Plates	14
Accessories and Applications	
Multi-Floor Velcro Driver Plate	15
AgiClean Pad & SuperZorb Pad	
UltraLift Pad, AkwaStrip Pad & StoneFlash Pads	16
Multi-Purpose Scrub Brush	17
Concrete Brush	
Operation/Maintenance (Application on Different Floors)	18
Carpet Cleaning, Cleaning Hard Floors	
Cleaning the Machine	
Changing the Driver Grip Face	
Part Diagrams and Part Lists	19 - 27
Wiring Diagram	Back Cover

HOW TO USE THIS MANUAL

This manual contains the following sections:

- How to Use This Manual
- Safety
- Operations
- Maintenance
- Parts List

The HOW TO USE THIS MANUAL section will tell you how to find important information for ordering correct repair parts.

Parts may be ordered from authorized dealers. When placing an order for parts, the machine model and machine serial number are important. Refer to the MACHINE DATA box which is filled out during the installation of your machine. The MACHINE DATA box is located on the inside of the front cover of this manual.

The model and serial number of your machine is located on the left side of the handle, from the operators perspective.

The SAFETY section contains important information regarding hazardous or unsafe practices of the machine. Levels of hazards are identified that could result in product damage, personal injury, or severe injury resulting in death.

The OPERATIONS section is to familiarize the operator with the operation and function of the machine.

The MAINTENANCE section contains preventive maintenance to keep the machine and its components in good working condition. They are listed in this general order:

- Storage
- Maintenance
- Troubleshooting

The PARTS LIST section contains assembled parts illustrations and corresponding parts list. The parts lists include a number of columns of information:

- REF – column refers to the reference number on the parts illustration.
- PART NO. – column lists the part number for the part.
- PRV NO. – reference number.
- QTY – column lists the quantity of the part used in that area of the machine.
- DESCRIPTION – column is a brief description of the part.
- SERIAL NO. FROM – If this column has an (*) and a Reference number, see the SERIAL NUMBERS page in the back of your manual. If column has two asterisk (**), call manufacturer for serial number. The serial number indicates the first machine the part number is applicable to. The main illustration shows the most current design of the machine. When a boxed illustration is shown, it displays the older design.
- NOTES – column for information not noted by the other columns.

NOTE: If a service or option kit is installed on your machine, be sure to keep the KIT INSTRUCTIONS which came with the kit. It contains replacement parts numbers needed for ordering future parts.

NOTE: The manual part number is located on the lower left corner of the front cover.

IMPORTANT SAFETY INSTRUCTIONS

When using this machine, basic precautions must always be followed, including the following:

READ ALL INSTRUCTIONS BEFORE USING THIS MACHINE.

WARNING

To reduce the risk of fire, electric shock, or injury:

- Use only indoors. Do not use outdoors or expose to rain.
- Use only as described in this manual. Use only manufacturers recommended components and attachments.
- If the machine is not working properly, has been dropped, damaged, left outdoors, or dropped into water, return it to an authorized service center.
- Do not operate the machine with any openings blocked. Keep openings free of debris that may reduce airflow.
- Machine can cause a fire when operating near flammable vapors or materials. Do not operate this machine near flammable fluids, dust or vapors.
- This machine is suitable for commercial use such as: in hotels, schools, hospitals, factories, shops, and offices for more than normal housekeeping purposes.
- Maintenance and repairs must be done by qualified personnel.
- During operation, use caution around other persons, especially children.
- The machine shall only be operated by instructed and authorized persons.
- When leaving unattended, unplug the machine.
- Do not handle the plug or machine with wet hands.
- Do not unplug machine by pulling on cord. To unplug, grasp the plug and not the cord.
- Do not use with damaged cord or plug. Follow all instructions in this manual concerning grounding the machine.
- Do not pull or carry by cord, use cord as a handle, close a door on cord, or pull cord around sharp edges or corners.
- Do not pull/run machine over cord. Keep cord away from heated surfaces.
- Connect to a properly grounded outlet. See Grounding Instructions.
- If the supply cord is damaged it must be replaced by an authorized service agent.
- Unplug before cleaning or servicing.
- Operational hazard may occur when running the machine over the supply cord.
- This appliance has been designed for use with pads specified by the manufacturer. The fitting of other pads may affect its safety.
- This machine is for dry use only and shall not be used or stored outdoors in wet conditions
- Moving Parts - To reduce the risk of injury, unplug before servicing.

READ AND SAVE THESE INSTRUCTIONS

SAFETY

The following symbols are used throughout this guide as indicated in their descriptions:

HAZARD INTENSITY LEVEL

There are three levels of hazard intensity identified by signal words -**WARNING**, **CAUTION**, and **FOR SAFETY**. The level of hazard intensity is determined by the following definitions:



WARNING - Hazards or unsafe practices CAN result in severe personal injury or death.



CAUTION - Hazards or unsafe practices which could result in minor personal injury or product or property damage.

FOR SAFETY: To Identify actions which must be followed for safe operation of equipment.

Report machine damage or faulty operation immediately. Do not use the machine if it is not in proper operating condition. The following is information that signals some potentially dangerous conditions to the operator or the equipment. Read this information carefully. Know when these conditions can exist. Locate all safety devices on the machine. Please take the necessary steps to train the machine operating personnel.

FOR SAFETY:

DO NOT OPERATE MACHINE:

- Unless trained and authorized.
- Unless Operation Guide is read and understood.
- In flammable or explosive areas.
- In areas with possible falling objects.

WHEN SERVICING MACHINE:

Avoid moving parts. Do not wear loose clothing, jackets, shirts, or sleeves when working on the machine. Use only manufacturer approved replacement parts.

TECHNICAL DETAILS

ITEM	SPECIFICATIONS
Motor	3/4HP, 360-600W, 15-25amp, 24V
Dual Speed	1725 RPM (Orbital), 100 RPM (Rotational)
Drive Diameter	17" (43.18 cm)
Wheel Diameter	10" (25.4 cm)
Solution Tank Capacity	3 Gallon (11.4L)
Pump	90 PSI (6.2 BAR)
Noise Level	59 dB
Height / Length / Weight	49" (124 cm) / 30" (76 cm) / 131 Lbs./59.42 Kg
Battery	Lithium-ion 2 x 24V/20Ah x 2
Run Time	Up to 2.5Hours (depending on floor/pad)
Charge Time	120 Minutes
Charge Type	Off board

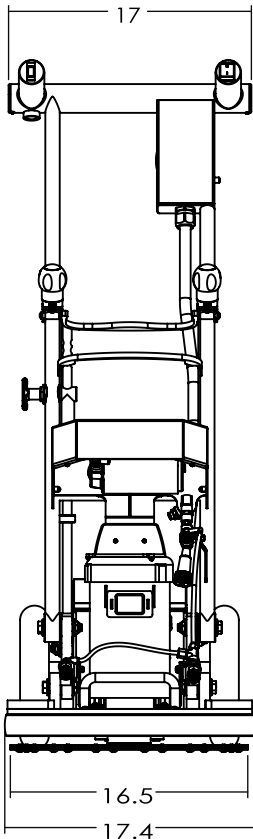

FRONT VIEW

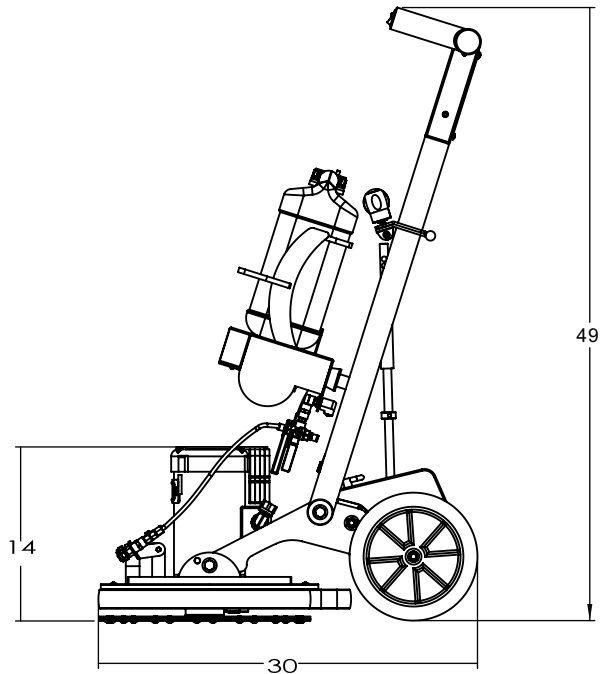

RIGHT SIDE VIEW

Unpacking and Initial Operations

Open shipping box (both sides). Remove packaging material. Roll machine out of box.

Pre-Run Inspection

Before each use, inspect for cracks, tears or excess wear. If the machine or accessory is dropped, inspect for damage. Then repair or replace, if necessary, before use.

- 1** - Tilt head back and place the foot of bumper on the ground. Choose a pad for the appropriate application.
- 2** - Center the pad on driver plate.
- 3** - Then position handle in a lower position.
- 4** - Push slowly forward until machine base tilts towards the ground.

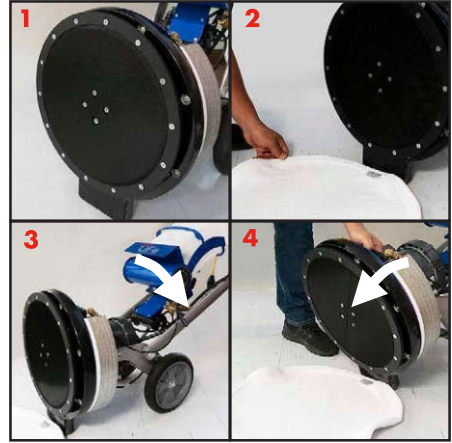

⚠ CAUTION

Make sure to put the wheels back on the ground in time to avoid the base from falling on the ground. This might cause damage! Check that the power switch is in the "off" position.

Battery Installation

Ensure battery is charged before using machine.

- **(FIGURE A)** Open the cover of battery box.
- **(FIGURE B)** Install double batteries.
- **(FIGURE C)** Close the cover of battery box.

To reinstall the battery, reverse the steps above.

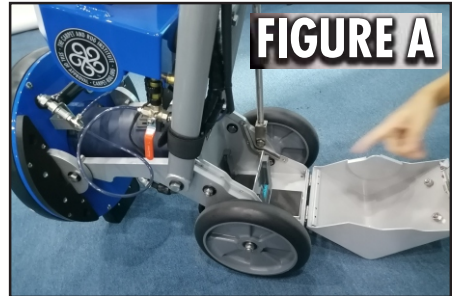

⚠ CAUTION

VERY IMPORTANT TIP!

ALWAYS FULLY CHARGE BATTERY IMMEDIATELY after each use!
DO NOT STORE DISCHARGED BATTERY!
RESULT: Will VOID battery warranty!

OPERATION

• (FIGURE D)

Plug the supplied power cord into the Battery Charger before it is plugged into an outlet.

• (FIGURE E,F,G,H)

Charging Battery Packs:

Connect AC power supply when green switch is off, turn on the green switch, and then connect the battery packs. Please following the operation sequence carefully.

- Universal Input: 100~240 50/60Hz
- Output Short-Circuit Protect Function. (In standby mode, output voltage shall be 0V. It also prevents electric shock when battery packs are connected to charger.)
- When the red LED light and the LCD screen flash quickly, it indicates that the battery pack is completely discharged. It will attempt an initial charge for 2-5 minutes. If it keeps blinking, it indicates battery pack failure and that the battery pack can no longer be recharged. If after 3 minutes of rapid charging, the battery pack voltage can't reach at least 21.0V(3V/cell), the charge will be terminated and the red LED 2Hz light will quickly flash.
- The charger is designed so that battery packs cannot be inserted with the polarity reversed.
- The charger LCD screen will display charge status and battery pack voltage and capacity.
- When the charge current drops to 300mA, the battery pack is fully charged. The green LED light will turn ON, the LCD screen will display the fully charged status, and the charging current will turn OFF.
- The charger will prevent the battery pack from slowly discharging when the charger does not have AC Input Power.
- When a fully charged battery pack is left in the charging stand for a prolonged period, and if the battery pack voltage drops to 28.0V, the charger will automatic recharge the battery pack.
- During rapid charging status, if the LED light turns off and the LCD screen stops running, the Battery Management System has determined that the battery pack is fully charged even if the display did not register 100%.

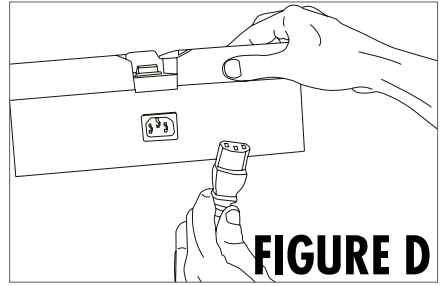

FIGURE D

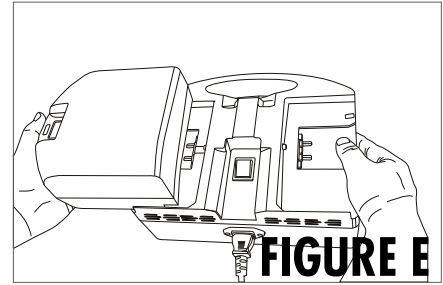

FIGURE E

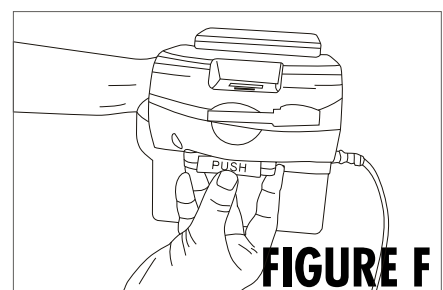

FIGURE F

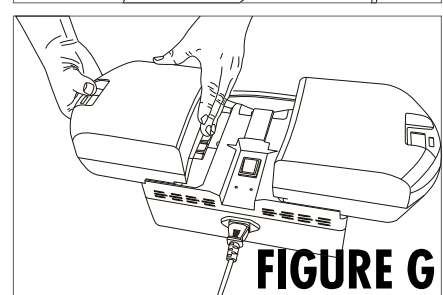
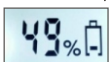

FIGURE G

LCD Display

With Battery Capacity and Charge Dynamic symbols:



LED Display

FIGURE H

Charger Stage	DOUBLE COLOR LED	
	RED	GREEN
Power ON	OFF	OFF
Rapid Charge	1Hz Flash	OFF
Fully Charged	OFF	ON
Battery Failure	Quickly Flash	OFF

OPERATION

Spray System Preparation

Fill bottle cartridge with suggested cleaning solution. Prime pump system by moving valve lever to the vertical position and depress spray switch for 30 seconds. By adjusting valve lever you can vary spray pressure. The further you move the lever counterclockwise upwards, the higher the water pressure. A horizontal position means maximum water output at maximum pressure. To turn the machine on, press the power button on the end of the left handle.

Spray Jets

Adjust spray jets on machine base to the desired position. For most floor cleaning applications, adjust spray jets so they spray about 6 inches (15 cm) in front of the base.

Adjusting Height

Set handle position to desired height by pulling and releasing the black knob with the left hand. While holding the black knob out, raise or lower the handle frame with your right hand. To secure handle frame, release the black knob so that it locks firmly into one of the holes provided. Position "0" is off and position "I" is on.

CAUTION

Make sure a suitable pad or brush is mounted before starting the machine. The immediate contact to floor and driver plate, without a pad, can lead to serious damage to the floor and/or the machine.

Process of Cleaning

For effective floor cleaning, move the machine forward and backwards. It is recommended to wet the floor as you move the machine forward, releasing the solution button when you move the machine backwards. To increase the pressure and cleaning effect on certain floor types like tile and grout, you can lift the machine frame up, raising the wheels off the ground. When lifting the wheels off the ground the full weight of the machine lies on the machine base.

CAUTION

Make sure the surface to be cleaned is not damaged by the increase in pressure. Omit this measure on very sensitive floors.

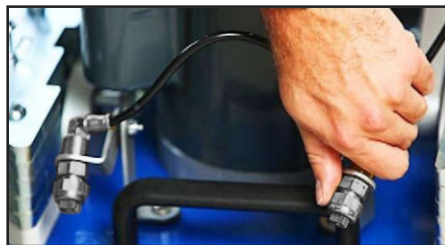

End of the Application

Turn off the machine by putting the on/off switch to "O". If a cleaning solution was used, fill bottle cartridge with water and spray out system for 30 seconds. Make sure to not let solution come in contact with the motor.

Storage

To avoid damage to the handle frame, do NOT lay machine frame on floor as done with other traditional cleaning equipment. Remove the pad from the driver plate by pulling it down firmly. Put machine frame in an upright position by pulling the black knob with the left hand and move the handle frame upwards with the right hand. The black knob should lock firmly in the top hole.

⚠ CAUTION

To allow for easy transportation of the machine, remove the weight kit if used.

To easily roll machine, push your foot on the back wheel axle and pull handle towards you. Moving machine similar to a dolly. Always store with the base in the upright position.

Lifting and Carrying

Without a ramp, we recommend 2 people to lift machine in and out of vehicle setting wheels down first, then base. Lock handle in a lower position. Make sure that the machine base rests on a pad, so that the grip surface of the driver plate does NOT get damaged or hooked onto a carpeted surface.

Grip the machine from each side as shown.

⚠ WARNING

Do NOT grip too close to the machine base. If the base should flip upwards it can cause serious hand injury.

Lift machine with a back-friendly posture. And then secure machine firmly so it will not move.

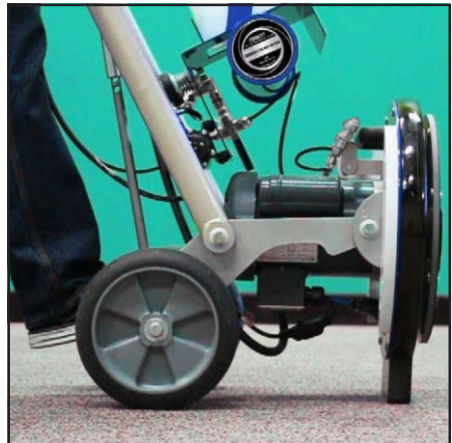
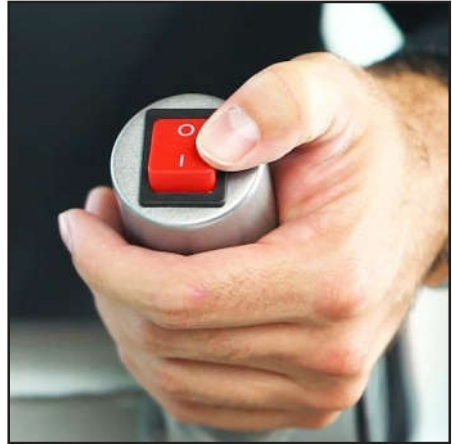

OPERATION

Weight Kit Installation

Place the weight kit (40 lbs.) on top of the mounting plates located on the sides of the machine base.

Put the 4 screws into the holes provided on the weight plates and fasten by turning clockwise.

Once the screws have threaded at least 5 full turns, tighten wing nuts by turning clockwise, until the weights fit securely to the base.

CAUTION

Make sure that the weights are securely attached to the base. Loose weights can cause serious damage.

For storage and transport, we recommend removing the weight kit. The machine can be transported more easily without the weights.

Brush Installation

Put the machine base in an upright position, sitting on the foot of the bumper. Remove the driver plate by removing the four countersink screws in the center of the plate using an electric screwdriver.

WARNING

It is important to only use a # 3 Phillips head screwdriver bit. Smaller bit sizes can damage the screw heads and leave sharp edges, which can tear or snag the pads. Damaged screws can cause further damage.

Mount the brush with the same countersink screws used for mounting the driver plates.

- **NOTE:** Tighten the screws sufficiently to avoid disengagement of the brush from the machine during operation.

To avoid stripping the screws, do NOT over tighten. An electric screwdriver with a clutch will ensure that stripping will NOT occur.



Attaching and Removing the Driver Plates

Put the machine base in an upright position, sitting on the foot of the bumper.

Remove the driver plate by removing the four countersink screws in the center of the plate using an electric screwdriver.

Attach a driver plate to the machine base by lining up the holes of the driver plate with the appropriate threads of the bearing retainer ring.

It is recommended to align the threads of the bearing horizontally to the ground.

Put the 4 countersink screws through the holes of the driver plate and first screw them into the bearing retainer ring threads manually. Then, tighten the screws with an electric screwdriver

⚠ WARNING

It is important to only use a # 3 Phillips head screwdriver bit. Smaller bit sizes can damage the screw heads and leave sharp edges, which can tear or snag the pads. Damaged screws can cause further damage.

- **NOTE:** Tighten the screws sufficiently to avoid disengagement of the driver plate from the machine base during operation.

To avoid stripping the screws, do NOT over tighten. An electric screwdriver with a clutch will ensure that stripping will NOT occur.

ACCESSORIES AND APPLICATIONS

⚠ WARNING

Never store the accessories in wet conditions. Keep the accessories away from extreme heat and from chemicals.

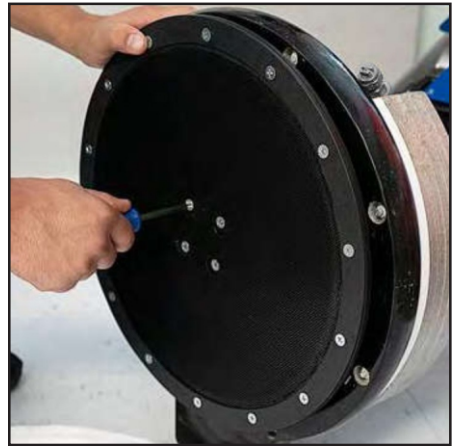

OPERATION

Multi-Floor Velcro Driver Plate

Exclusively use designated driver plates only. Using other driver plates will damage the machine and its mechanical action. Driver plates are fastened on the machine base with four countersink screws.

The 17" driver plate supplied is suitable for all pads on textile and hard floor applications. Pads can be easily attached and removed from the driver disc.

WARNING

Never place driver on carpet without a pad attached. May cause damage to the floor.

AgiClean Pad

The beige AgiClean pad is made of a special blend of fibers and latex that allows gentle cleaning of heavily soiled short-pile carpets as well as scrubbing of hard floors. Attach the AgiClean pad by centering on the driver plate.

AgiClean pads, used on both sides, cleans an approximate area of 3,000 sq. ft. (280m²), depending on floor type and level of soil. Rinse the AgiClean pads after each use with clean water.

SuperZorb Pad

Our exclusive SuperZorb pad is made of a special cotton and polyester blend. One of the primary components that help to extract an essential amount of soil from the carpet fibers. They also play an important role to achieve fast dry times.

SuperZorb pads, used on both sides, cleans approximately 30,000 sq. ft. (2800m²) with up to 100 washes. This of course depends upon floor type and level of soil. SuperZorb pads are also machine washable. Allow to air dry.

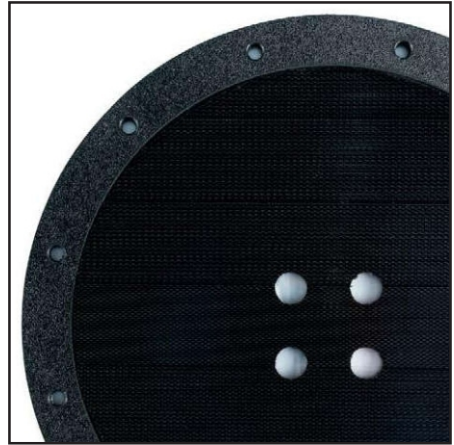

OPERATION

UltraLift Pad

The UltraLift pad can be used on stone, concrete, VCT, marble and porous surfaces.

Each pad can clean an approximate area of 4,000 sq. ft. (372m²) depending on floor type and level of soil.

AkwaStrip Pad

The AkwaStrip pad is a chemical free stripping pad made of a unique material filled with diamonds. Used for deep cleaning and to remove wax off of vinyl, VCT, linoleum, wood, safety tiles and more. Used on both sides, can clean approximately 2,500 to 5,000 sq. ft. (230 to 460m²), depending on floor type and the level of wax/soil. Thoroughly rinse with clean water after use.

StoneFlash Pads

Our newly redesigned StoneFlash pads are part of a 5 step system for grinding, honing and polishing marble, terrazzo, travertine, limestone and more.

Each pad cleans an approximate area of 5,000 sq. ft. (460m²) depending on floor type and level of soil.

- **NOTE:** StoneFlash pads require the use of the ORBOT Weight Kit (sold separately).



Multi-Purpose Scrub Brush

The bristles of the brush are made of high quality nylon. The unique brush design is ideal for cleaning tile and grout, smooth concrete, rubber flooring and other microporous surfaces such as porcelain and safety tiles. It can also be used for any other hard surfaces.

⚠ CAUTION

The use of the multi-purpose brush may splash in certain applications. Take appropriate measures or use a splash guard to prevent the wetting of walls and other obstacles.

Rinse the brush as needed with clean water after each use. Depending on usage and care, you can use the multi-purpose brush for many years.

- **NOTE ON STORAGE:** Never store the multi-purpose brush with the bristles down. This can deform the bristles, damage the brush, and reduce the cleaning performance.

You can bring deformed bristles back into their original form by heating them with a heat gun.

Concrete Brush

Our concrete brush is designed for outside concrete and other rough surfaces. It is great for cleaning walkways with minimal water.

⚠ WARNING

Never use the concrete brush on any other floor other than specified outside concrete or rough surfaces, as this brush will cause serious damage to all other flooring.



APPLICATION ON DIFFERENT FLOORS

Carpet Cleaning

Vacuum the carpet thoroughly before cleaning. Large dirt particles are removed, allowing the application to be more effective.

Apply solution while moving forward. Clean by going forward and backwards 2 to 3 times, while applying solution on the first pass in order to keep the drying time low. Depending on soil level and nature of the carpet, this process can be shortened or extended. As required, carpets can be vacuumed again after cleaning.



Cleaning Hard Floors

Remove dust and coarse dirt from the surface before cleaning. Choose a suitable pad according to the application. Place the pad in the center of the driver. Gently lower the head on to the floor. Moving forward and backwards while adding water to the surface. Use cleaning solution as needed. Depending on soil contamination and floor type, this process can be shortened or extended.

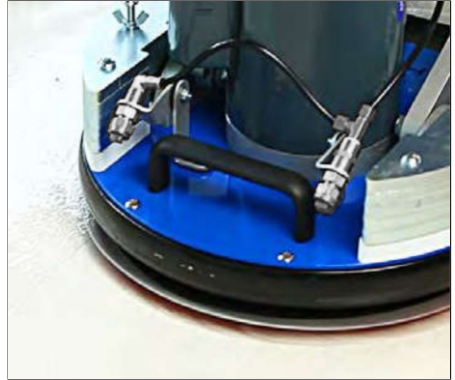

Cleaning the Machine

Clean the machine and bearing with a soft cloth and a neutral pH cleaner. Regular cleaning of the bearing is required to prevent build up that will cause it to seize up.

Changing the Driver Grip Face

Remove the 10 outer screws that fasten the grip face disc on the driver plate. To save time, use an electric screwdriver with a #3 Phillips head bit.

WARNING

The #3 Phillips head bit is slightly larger than standard size. It is important that you are using a #3 Phillips head bit, as smaller bits can damage the screw heads and produce sharp edges which can damage the cleaning pads. Attach a new grip face disc to the driver plate using the 10 screws.

Make sure that the screws are very tight, not loose. If the screws are too loose, it can cause damage to the grip face disc. Ensure that the 4 holes in the middle of the grip face disc are aligned with the screws located on the driver plate. An exact alignment allows an easy removal and installation of the driver plate.

PARTS

WHEEL & BATTERY CAGE ASSEMBLY

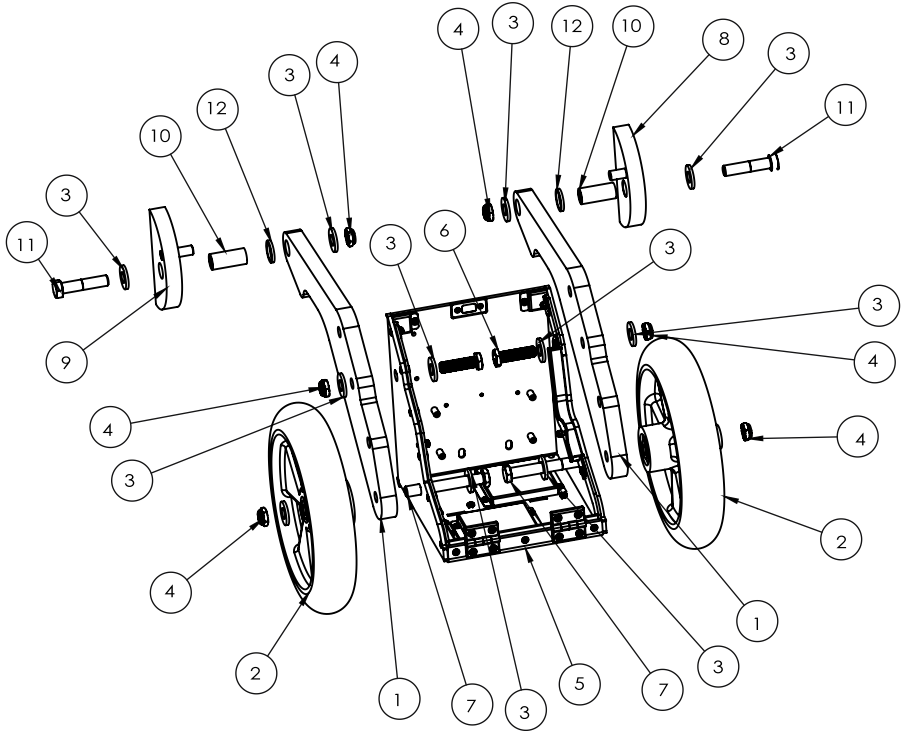

ITEM NO	PART NUMBER	PART NUMBER I-TEAM	QTY	DESCRIPTION
1	40-019	L.120.1620.36	2	LIFE ARMS, LEFT&RIGHT
2	4003	120.0437.0	2	04-010 WHEEL, 10"
3	4010	120.0418.0	12	01-004 WASHER, PLASTIC, .500 X .125 X 1.125OD
4	4011	120.0415.0	6	01-002 HEX NUT, LOCK, .5-13 X .75W X .312H
5	40-018	120.0782.0	1	BATTERY CAGE, WELD ASSY
6	01-042	120.0419.1	2	ZINC PLATED, 1/2"-13, 1-3/4" LONG
7	01-057	120.0522.1	2	01-057 SUS SCREW, 1/2"-13x3-3/4" THIN
8	3007-051	L.120.1520.36	1	40-016 LEFT EAR (with pin)
9	3007-052	L.120.1521.36	1	3007-052 RIGHT EAR (with pin)
10	2024-2	120.0625.0	2	(40-011)ARMS PLASTIC BUSHING ODO.748"/IDO.5" 1.65" LENGTH
11	4009	120.0524.0	2	4009 SCREW, 1/2-13 X 2-1/4";HH, STL, ZNPLT
12	01-046	120.0427.0	2	01-046 NYLON PLASTIC WASHER 0.812"ID, 1.057"OD

HANDLE / FRAME ASSEMBLY

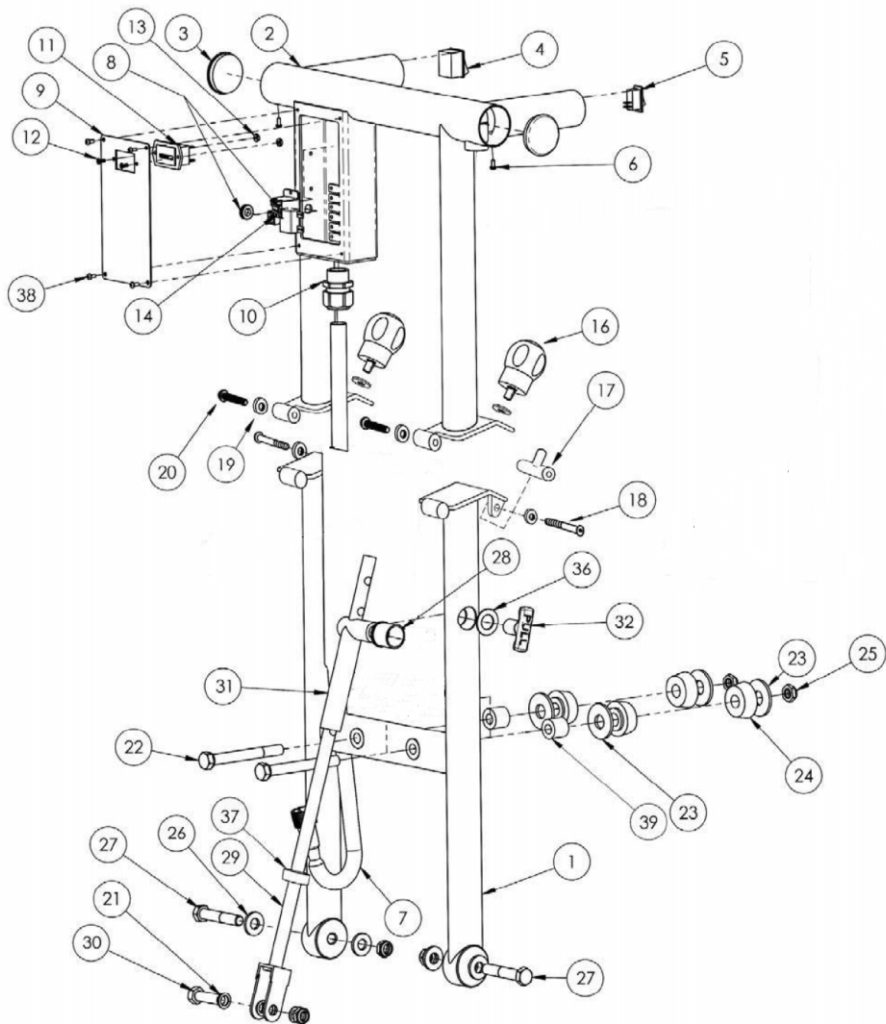

PARTS

HANDLE / FRAME ASSEMBLY

ITEM NO	PART NUMBER	PART NUMBER I-TEAM	QTY	DESCRIPTION
1	10-010	L.120.1626.36	1	LOWER FRAME, WELD ASSEMBLY
2	1000-06U	L.120.1627.36	1	HANDLE ASSEMBLY, UPPER, WITH ELECTRICAL BOX
3	1015	120.0540.0	2	CAP, TUBE HANDLE, 2" DIA
4	1005-03	120.0406.0	1	SWITCH, ROCKER, ON/OFF, DOUBLE POLE
5	1007	120.0119.0	1	SWITCH, ROCKER, SPRAYER, DOUBLE POLE
6	1016	120.0541.0	6	SCREW, 6-20 x .38, TUBE CAP
7	03-015X	S.120.0628.0	1	WIRE HARNESS ASSEMBLY
8	03-014	120.0655.0	1	CIRCUIT BREAKER 40 AMP
9	10-044	L.120.1631.36	1	TERMINAL BOX COVER
10	3031	120.0682.0	1	CORD GRIP, 1", MOTOR
11	03-017	120.0630.0	1	HOUR RUN TIME METER
12	01-041	120.0550.0	2	SCREW, 6-32 X .375
13	01-053	120.0120.0	2	HEX NUT, 6-32 X 5/16"
14	03-018	120.0349.0	1	RELAY, PANEL MOUNT
16	1003-08	120.0526.0	2	KNOB, LOCKING POSITION
17	1003-152	120.0527.0	2	"T" SCREW, KNOB, HANDLE
18	1002-2	120.0528.0	2	SCREW, 1/4-20, 1.5", HANDLE, LOWER HINGE
19	1021-1	120.0532.0	8	WASHER, NYLON, KNOB & HINGE ASSEMBLY
20	1002-1	120.0543.0	2	SCREW, 3/8-16, 1.25", HANDLE, UPPER HINGE
21	1029	120.0416.0	6	WASHER, NYLON, .5 ID X .75 OD X .06 THK
22	01-055	120.0611.0	2	HEX CAP SCREW, 1/2-13 X 4-1/2
23	2021	120.0511.0	4	WASHER, 5/8" X 1-3/4" X .134"
24	2023	120.0505.0	4	DAMPNER, RUBBER
25	4011	120.0415.0	5	HEX NUT, LOCK, .5-13 X .75W X .312
26	4010	120.0418.0	4	PLASTIC WASHER, .5 ID X 1.125 OD X .125 THK
27	1019	120.0529.0	2	HEX CAP SCREW, .5-13 X 2-3/4, LOWER HANDLE
28	10-016	120.0605.0	1	PLASTIC BUSHING, OUTER PULL LATCH
29	10-017	120.0602.0	1	OUTER PULL LATCH, ROD WELD ASSEMBLY
30	01-042	120.0419.1	1	HEX CAP SCREW, .5-13, 1-3/4"
31	10-019	120.0603.0	1	WELD ASSEMBLY, OUTER PULL LATCH
32	10-020	120.0604.0	1	PULL LATCH, T-KNOB
36	01-067	120.0606.0	1	WASHER, NYLON, .765" ID X 1.312" OD X .62"
37	1027	120.0417.0	1	SHAFT COLLAR, SET SCREW, .63 ID X 1.13 OD X .5"
38	1012	120.0116.0	4	SCREW, 8-32 X .25", ELECTRICAL BOX COVER
39	2024-2	120.0625.0	2	BUSHING, PLASTIC, .75"OD X .5"ID X 1.625"

PUMP & TANK CAGE ASSEMBLY

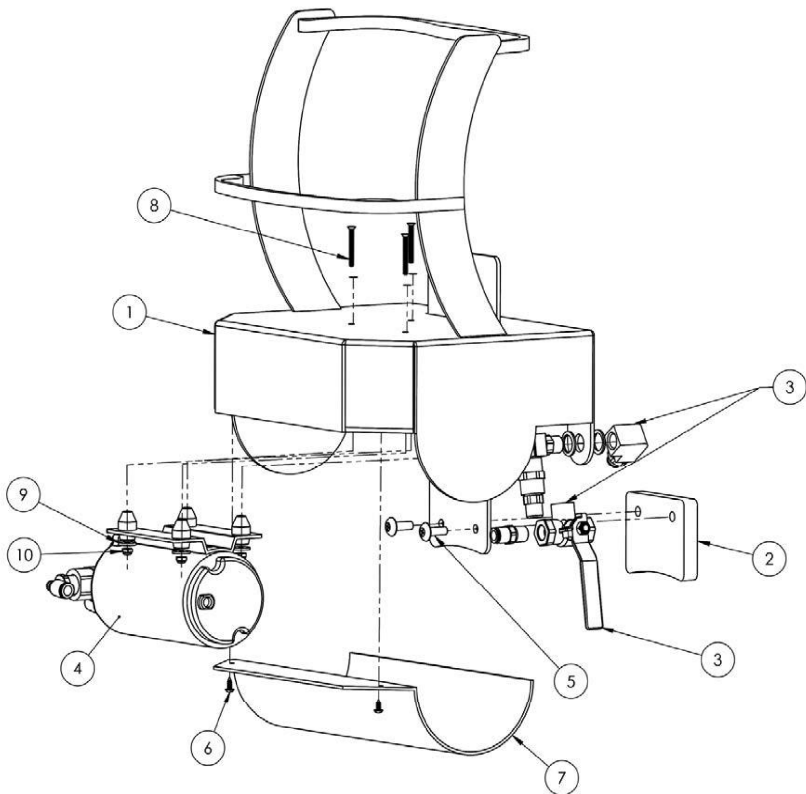

ITEM NO	PART NUMBER	PART NUMBER I-TEAM	QTY	DESCRIPTION
1	20-003	L.120.1607.701	1	CAGE ASSEMBLY, BOTTLE HOLDER
2	20-017	120.0608.0	1	CAGE PVC STOPPER ASSEMBLY
3	04-015	S.120.0581.0	1	VALVE SYSTEM ASSEMBLY
4	30-031	120.0654.0	1	PUMP, DC, 90° PSI
5	01-010	120.0609.0	2	SCREW, .25-20 X .75
6	01-059	120.0541.0	2	SCREW, N6, 3/8"
7	20-018	L.120.1648.701	1	CAGE BOTTOM COVER
8	2012	120.0642.0	4	SCREW, 6-32 X 1-1/4"
9	2014	120.0436.0	4	WASHER, PUMP MOUNT
10	2013	120.0120.0	4	HEX NUT, 6-32, NYLOCK, PUMP MOUNT

TANK, BATTERY & CHARGER ASSEMBLY

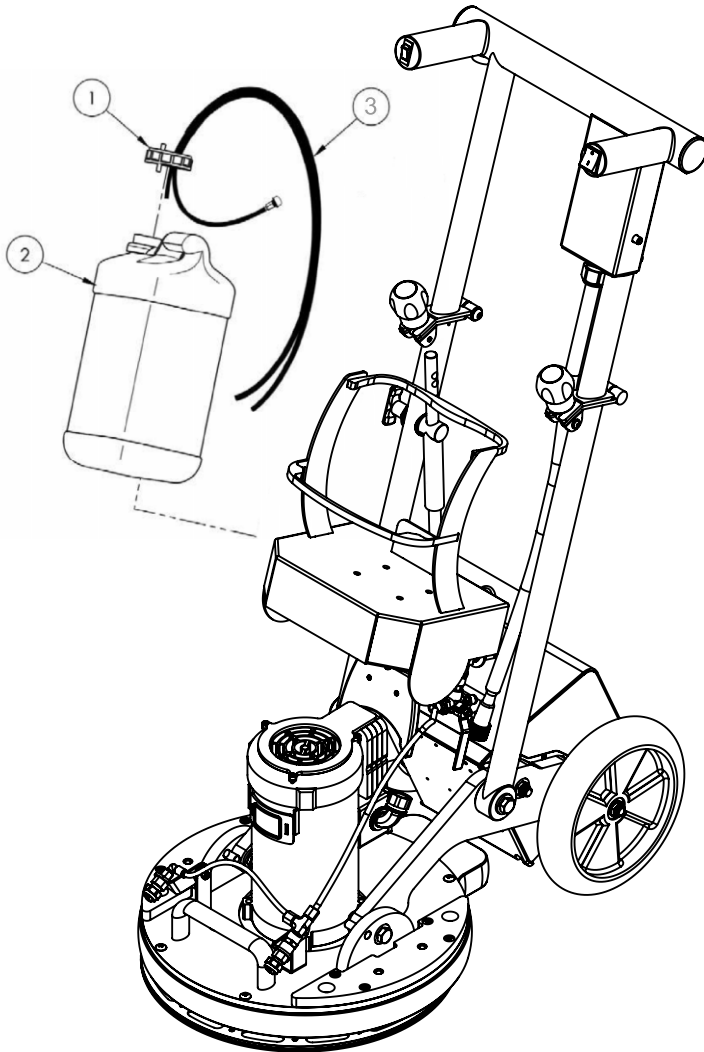

ITEM NO	PART NUMBER	PART NUMBER I-TEAM	QTY	DESCRIPTION
1	2018	S.120.0508.0	1	BOTTLE CAP ASSEMBLY
2	2019	120.0506.0	1	SOLUTION TANK, 3 GALLON
3	2015-02L	S.120.0643.0	1	BOTTLE CARTRIDGE HOSE ASSEMBLY

MOTOR & BASE ASSEMBLY

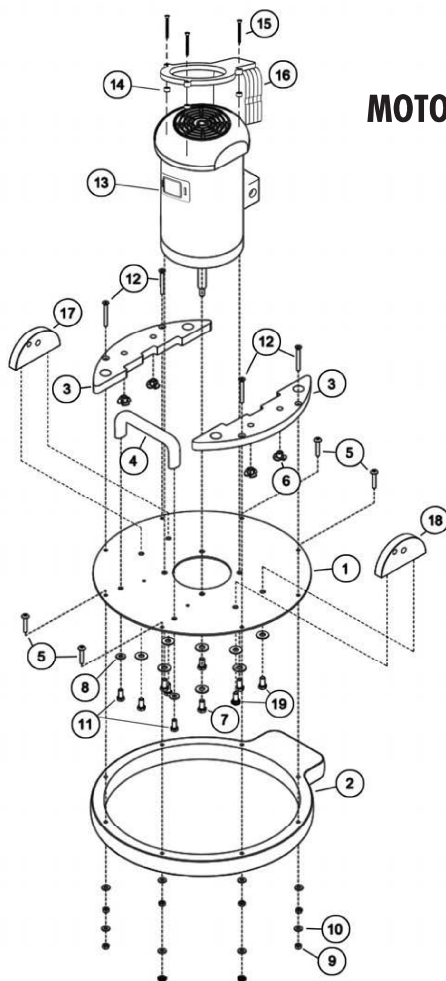

ITEM NO	PART NUMBER	PART NUMBER I-TEAM	QTY	DESCRIPTION
1	40-013	L.120.1615.701	1	BASE PLATE, .375 THK
2	3001-19	S.120.0446.0	1	BUMPER, 19"
3	3045-14	S.120.0514.0	2	WEIGHT PLATE ASSEMBLY
4	3004	120.0515.0	1	HANDLE, BASE
5	01-048	120.0617.0	4	SCREW, 1/4-20 X 1-3/4", BASE MOUNT
6	3045-06		4	NUT, 1/4-20 X 5/16, TEE, 4 PRONG
7 / 8	3034 / 3035	120.0658.0 120.0424.0	4 / 10	SCREW, HEX, .38-16 X .75" / WASHER, 3/8" ID X 1" OD
9 / 10	3003 / 3003-02	120.0652.0 120.0444.0	8 / 8	HEX NUT, 1/4-20, BUMPER / WASHER, 1/4" ID X 5/8" OD
11 / 12	3006 / 01-049	120.0656.0 120.0518.0	2 / 4	SCREW, 5/16-18 X 3/4" / SCREW, 1/4-20 X 2-1/4"
13	3023-01	120.0635.0	1	MOTOR, DC 24V
14	05-007	120.0637.0	3	RUBBER BUMPER SUPPORT, 3/8" OD
15	01-066		3	SCREW, 8-32 X 1-3/4"
16	30-030	L.120.1636.704	1	REAR MOUNT, MOTOR WEIGHT ASSEMBLY
17 / 18	3007-051 / 3007-052	L.120.1520.36 L.120.1521.36	1 / 1	LEFT EAR WITH PIN / RIGHT EAR WITH PIN
19	01-050	120.0618.0	4	SCREW, HEX, .38-16 X 1.25"

PARTS

MOTOR ASSEMBLY

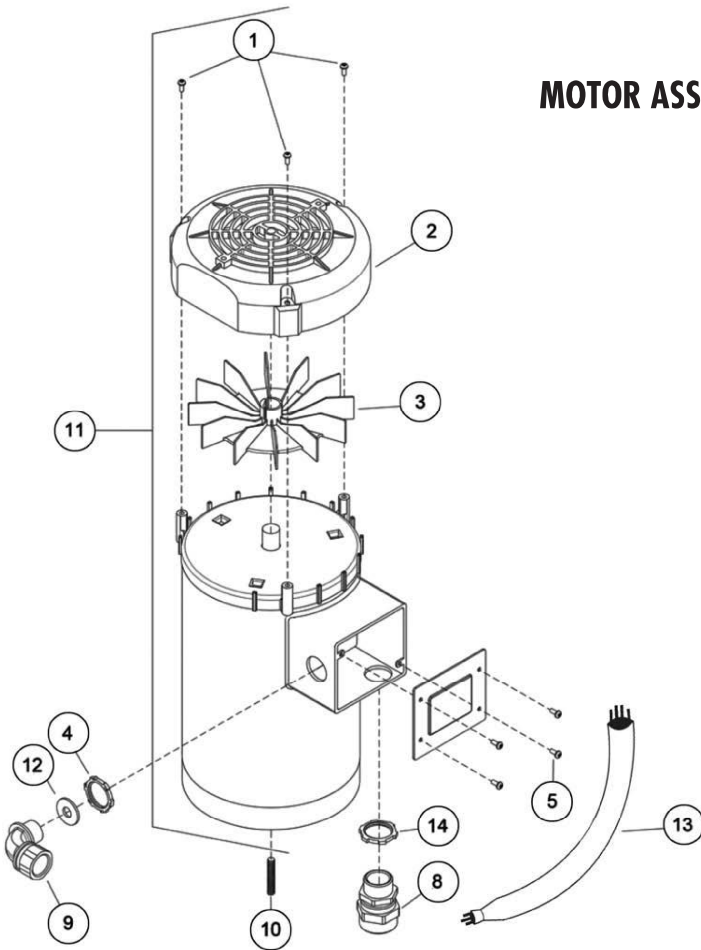

ITEM NO	PART NUMBER	PART NUMBER I-TEAM	QTY	DESCRIPTION
1	3023-05	120.0638.0	3	SCREW, FAN COVER, 10-32 X 3/8"
2	3023-04		1	COVER, FAN MOTOR
3	3023-03		1	FAN, MOTOR
4/14	1014/3030	120.0451.0	2	LOCK NUT, 1/2"/LOCK NUT, 1" - ELECTRICAL BOX
5	01-047		4	SCREW, FLAT HEAD , N10. 1"L
6	3032		1	CORD, BLUE PLUG, 100-120V, PUMP
7	3033		1	CORD, BLACK PLUG, 100-120V, AUX
8	3031	120.0682.0	1	CORD GRIP, 1", MOTOR
9	3029	5.120.0452.1	1	ELBOW, 3/4", ELECTRICAL BOX
10	3024	120.0453.0	1	SOCKET SET SCREW .38-24 X 1.50
11	3023-01	120.0635.0	1	MOTOR, DC, 24V
12	3023-02		1	WASHER, SERRATED, 3/4", CORD GRIP
13	3028		1	HARNES, MAIN HANDLE

SPRAY NOZZLE ASSEMBLY

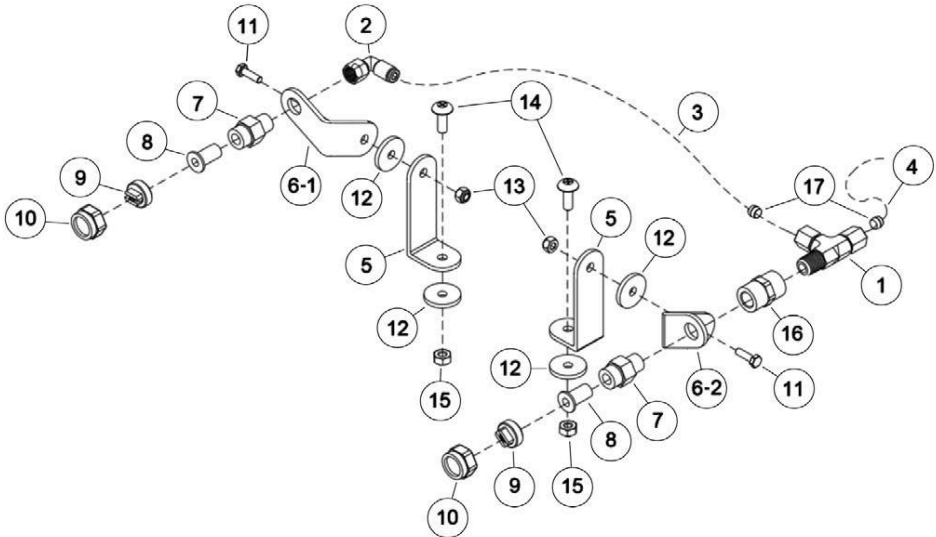

ITEM NO	PART NUMBER	PART NUMBER I-TEAM	QTY	DESCRIPTION
1	3019	120.0465.0	1	QUICK CONNECT, 1/4", TEE, SPRAY NOZZLE
2	3021	120.0667.0	1	ELBOW, 90°, SPRAY NOZZLE
3	3022	120.0557.0	1	SPRAY JET HOSE
4	3022-01	120.0558.0	1	SPRAY JET T-HOSE
5	3009	120.1559.1	2	L-BRACKET, NOZZLE BASE
6 - 1	3010-001	120.1560.1	1	SPRAY JET BRACKET LEFT ASSEMBLY
6 - 2	3010-002	120.1561.1	1	SPRAY JET BRACKET RIGHT ASSEMBLY
7	3016	120.0068.0	2	SPRAY JET BODY
8	3015	120.0562.0	2	CHECK VALVE STRAINER
9	3014	120.0663.0	2	SPRAY JET TIP
10	3017	120.0664.0	2	SPRAY CAP
11	3011	120.0563.0	2	SCREW, 10-32 X 3/4", SPRAY JET ARM
12	3013	120.0564.0	2	WASHER, SPRAY JET ARM
13	3012	120.0565.0	2	HEX NUT, 10-32, NYLOCK, SPRAY JET ARM MOUNT
14	3036	120.0308.0	2	SCREW, 1/4-20 X 3/4", SPRAY BRACKET MOUNT
15	3037	120.0567.0	2	HEX NUT, 10-32, NYLOCK, SPRAY BRACKET MOUNT
16	3020	120.0473.0	1	COUPLER, FLOW JET
17	3019-01		2	SLEEVE, COMPRESSION

DISC DRIVE ASSEMBLY

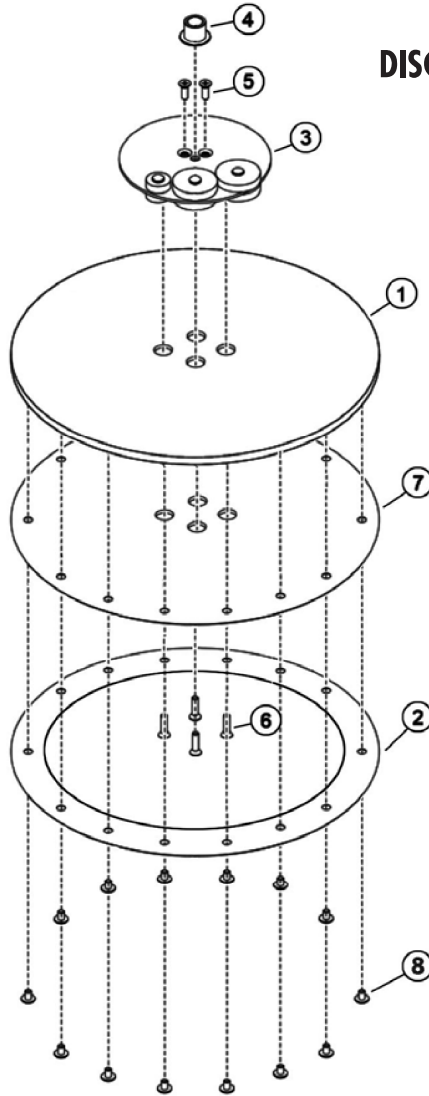

ITEM NO	PART NUMBER	PART NUMBER I-TEAM	QTY	DESCRIPTION
1	MFD19	120.0568.0	1	DRIVER, DISC, 19"
2	MFVR19	120.0569.0	1	RING, MULTI-FLOOR DRIVER, 19"
3	3026	S.120.0572.0	1	COUNTERWEIGHT ASSEMBLY, INCLUDES BEARING
4	3025	120.0454.0	1	SHAFT SUPPORT
5	3026-17	120.0328.0	2	SCREW, 1/4-20 X 3/4", COUNTER WEIGHT ASSY
6	3047	120.0457.0	4	SCREW, 1/4-20 X 1", DRIVER PLATE
7	MFVDP17	120.0570.0	1	PAD, VELCRO
8	3042-1	120.0571.0	14	SCREW. 1/4-20 X 3/8, VELCRO DRIVER PLATE

WIRING DIAGRAM

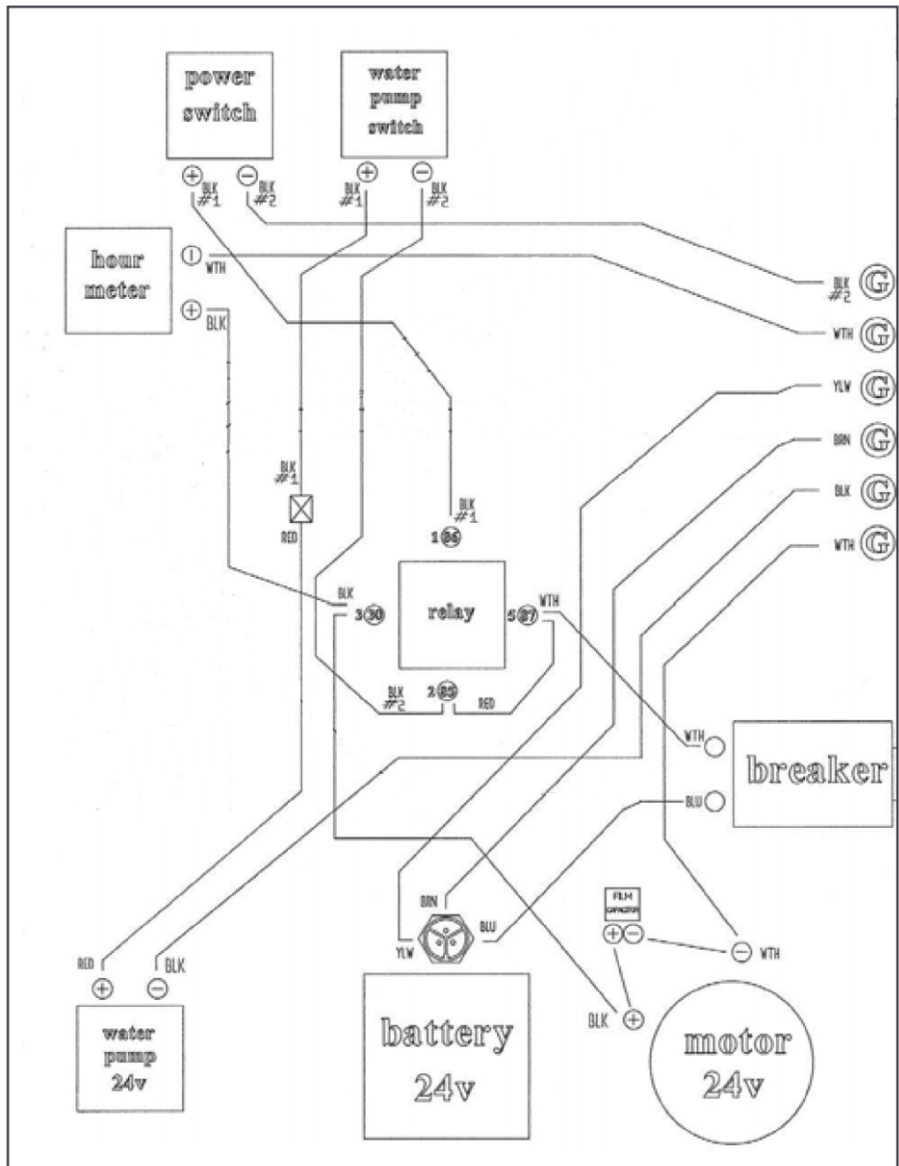

EC DECLARATION OF CONFORMITY

We: **Orbot Global BV, Lage Zijde 3, 5626 DL Eindhoven, The Netherlands**
hello@orbotglobal.com, www.orbotglobal.com

Declare under our sole responsibility that the product: Scrubber

Floor

(Type of machine)

Orbot LIFE

(Model – serial number, year of production)

to which this declaration relates is in conformity with the following standards:

EN 60335-1, EN 60335-2-67

(Title and/or number and data of issue of the standard(s) or other normative document(s))

follow the provision of directives:

Machine directive: 2006/42/EC

Electro Magnetic Compatibility Directive: 2014 / 30 / UE

Eindhoven, 01.08.2022

Frank van de Ven
Director



(Place and Date of issue)

(name and signature or equivalent marking
or authorized person)

INTERNATIONAL WARRANTY POLICY for ORBOT Vibe, SprayBorg, LiFE, and SLiM.

All warranty repairs will be coordinated through your local distributor.

Transport is covered by ORBOT. Warranty labor is NOT covered by ORBOT.

A copy of all warranty claims will be emailed to warranty@orbitglobal.com for quality assurance reporting.

Warranty term: Each machine is made with care and covered for one (1) year against manufacturing defects effective from date of original purchase from manufacturer for parts ONLY.

- Charger 1 year warranty
- Battery 1 yer warranty or 800 charging cycles

Non-warranty items:

Powder Coat Finish

Velcro driver plate

Driver Plate Mounting Screws

All Accessories

User Negligence

ORBOT GLOBAL

Lage Zijde 3

5626 DL Eindhoven, The Netherlands

P: +31402662420

E: hello@orbitglobal.com

www.orbotglobal.com

「Your local distributor:」

」

」

This form must be completed in all applicable sections and returned with all relevant parts and other documents. Complete this form fully, Failure to fully complete the form will seriously affect prompt replacement / refund.

General information

Company name

Telephone number

Name

Email

Address

Date of purchase

City

Purchased from

Country

Technical information

Machine name

Run Hours

Part/ product number

Serial number machine(s)

Number of machines affected

Failure date

Description Symptom

Description symptom

Clear picture of machine ID plate

Additional picture 1

Additional picture 2

Check box
I declare that the information as mentioned above represents the returned goods

Signature
[Your local distributor:]

ORBOT GLOBAL

Lage Zijde 3
5626 DL Eindhoven, The Netherlands
P: +31402662420
E: hello@orbotglobal.com
www.orbotglobal.com

[]

ORBOT[®]



Orbot Global B.V.

Lage Zijde 3
5626 DL Eindhoven
The Netherlands

+31 40 266 24 94
hello@orbotglobal.com
www.orbotglobal.com

Distribution address
Flight Forum Unit 3
5657DX Eindhoven
The Netherlands
Loading docks 1 and 2
Loading flat floor dock 3

Loading address
Flight Forum Unit 2
5657DX Eindhoven
The Netherlands
Loading docks 5 and 6
Loading flat floor dock 4